



**YOUR  
BENEFIT:  
4 TO 10  
TIMES MORE  
RUNNING  
HOURS**

**BOOST YOUR PUMP PERFORMANCE  
WITH OUR NEW ANTI-STICKING  
PUMP ELEMENT**

## BENEFIT FROM THE ADVANTAGES OF AN ALL-NEW GENERATION OF PUMP ELEMENTS

Our customers' needs are in the foreground of every development we take on – and our new generation of anti-sticking pump elements is a perfect example. Deposits in the barrel often lead to the plunger sticking. This is most often the result of an incompatibility between the fuel and lubricating oil, i.e. low total base number values, and/or an incompatibility between different fuels.

With the new anti-sticking solution, we have succeeded in reducing the formation of deposits – therefore reducing the risk of sticking. Key benefits include increased time before overhaul (TBO) and reduced engine downtime which result in a 4- to 10-fold increase in length of performance. What makes this possible is the combination of an innovative coating together with targeted design optimizations. The hydraulic properties of the anti-sticking pump elements correspond exactly to those of the previous series pumps.

TAKE ADVANTAGE OF THE MANY BENEFITS OF AN ALL-NEW GENERATION OF PUMP ELEMENTS



### 4 TO 10 TIMES MORE RUNNING HOURS

Our special coating reduces deposits and significantly extends running hours compared to standard products

### LESS STICKING OF THE PLUNGERS

A microgroove with a scraper ring separates the lubricating oil from the fuel and reduces the building of deposits in the barrel

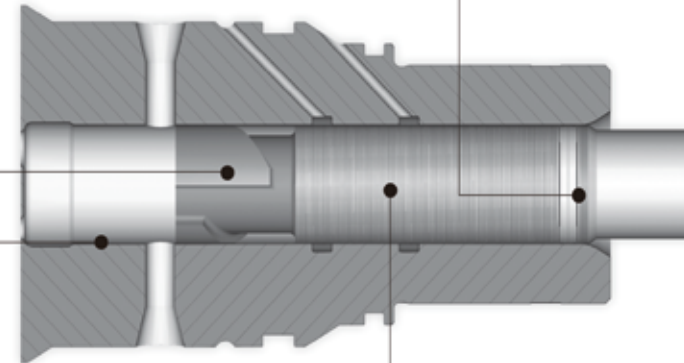

### REDUCED SERVICE REQUIREMENTS

The innovative anti-sticking solution ensures significantly longer maintenance intervals, therefore reducing service costs

### SUCCESSFUL APPLICATIONS

This new generation of pump elements has already been used successfully in many different applications

AN INNOVATION FROM WOODWARD L'ORANGE SERVING OUR CUSTOMERS' NEEDS FOR OPTIMIZED RUNNING PERFORMANCE

# IMPROVED RUNNING PERFORMANCE AND LONGER SERVICE INTERVALS WITH OUR ANTI-STICKING SOLUTION

The pump elements are already available for the following systems:

Engine type	IMO	FUEL PUMP TYPE	PUMP ELEMENT	COATED PLUNGER	NOTES
16/24	Tier I	PYO-G085A	PYO-U8031A	x	
	Tier II	PYO-G092C	PYO-U8045A	x	anti lacquer
21/31	Tier I	PDO-G017AV2	PDO-U824V3	x	anti lacquer
	Tier I	PDO-G017BV1	PDO-U825V1	x	
	Tier I	PDO-G017CV1	PDO-U818CV1	x	
	Tier II	PDO-G031B	PDO-U828A	x	anti lacquer
23/30	Tier I	PYO-G061D	PYO-U8047	x	low sulphur
	Tier I	PYO-G073G	PYO-U872AV1	x	low sulphur
27/38	Tier I	PEM-G008E	PEM-U816E	x	anti lacquer
28/32	Tier I	PYO-G062GY	PYO-U859EY	x	low sulphur
32/40 CD	Tier I	PEM-G009E	PEM-U818E	x	anti lacquer
	Tier I	PEM-G009F	PEM-U818F	x	

All parts can be exchanged retroactively.

**Challenge us – our experts will find the best possible solution for you.**

Contact our Sales team for more information about our solutions and how you can benefit from them. We look forward to hearing from you.

**email: [sales@lorange.com](mailto:sales@lorange.com) or email: [sales.asia@lorange.com](mailto:sales.asia@lorange.com)**

WOODWARD INC.

LINCOLN CAMPUS CORPORATE HEADQUARTERS  
1081 WOODWARD WAY, FORT COLLINS, COLORADO 80524, USA  
[WWW.WOODWARD.COM](http://WWW.WOODWARD.COM)

WOODWARD L'ORANGE GMBH

PORSCHESTRASSE 8, 70435 STUTTGART, GERMANY  
[WWW.LORANGE.COM](http://WWW.LORANGE.COM)